



COMPANY  
LIMITED



## BL-LD Series Fully Louvred Doors

a total **louvre design**  
and **manufacturing** service

### Index

	Page
BL50LD Aluminium louvred door	3
BL75LD Aluminium louvred door	4
BL50BF Insert louvres for doors	7

For more details on the Bridge Louvre  
Product range and equipment

Tel: 0161 338 5631

Fax: 0161 304 8269

Email: [sales@louvre.co.uk](mailto:sales@louvre.co.uk)



a total **louvre design**  
and **manufacturing** service

### BL-LD Series Fully Louvre Doors

#### Materials

Aluminium extrusions type 6063-T6 to BS1474 having a minimum thickness of 1.6mm.

#### Specification

Doors are provided fully framed for installation into customer formed and prepared structural openings. They can also be incorporated into louvre screens whilst maintaining a continuous appearance.

All doors are made to measure to suit customer dimensions. They are pre-hung in our factory before despatch to ensure alignment and correct operation.

Typical lead time: 2-3 weeks depending upon quantity, specification and finish. For urgent deliveries, please call the office to discuss current availability.

For further specification details, see following page.



a total **louvre design**  
and **manufacturing** service

### BL50LD Aluminium Louvred Door Specification

Standard outer box frame dimensions: 50mm x 100mm with hinge rebate.

Door leaf depth: 74mm

Hinges: 3 no. 100 x 75mm ball bearing butt hinges with pin secured by removable grub screw

Louvre Blade pitch: 50mm

Lock case :64mm euro profile deadlock to EN12209

Cylinder: Euro cylinder, keyed external, thumbturn internal.

Shoot bolts (double doors only): heavy duty brushed stainless steel 14mm diameter

Bird guard mesh: Galvanised after manufacture to BS443. Size 12.5mm x 12.5mm x 1mm. Fitted as standard.

Standard hardware correct as at January 2011 (may change without notice)

BL-LD Series Options are listed on page 7



a total **louvre design**  
and **manufacturing** service

**Single door**

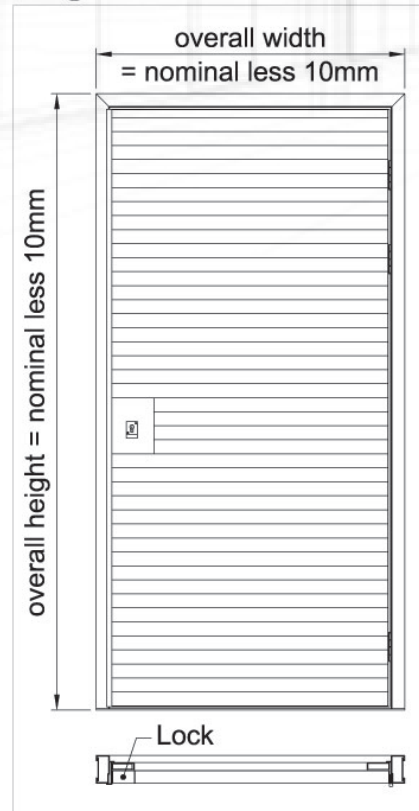

**Double door**

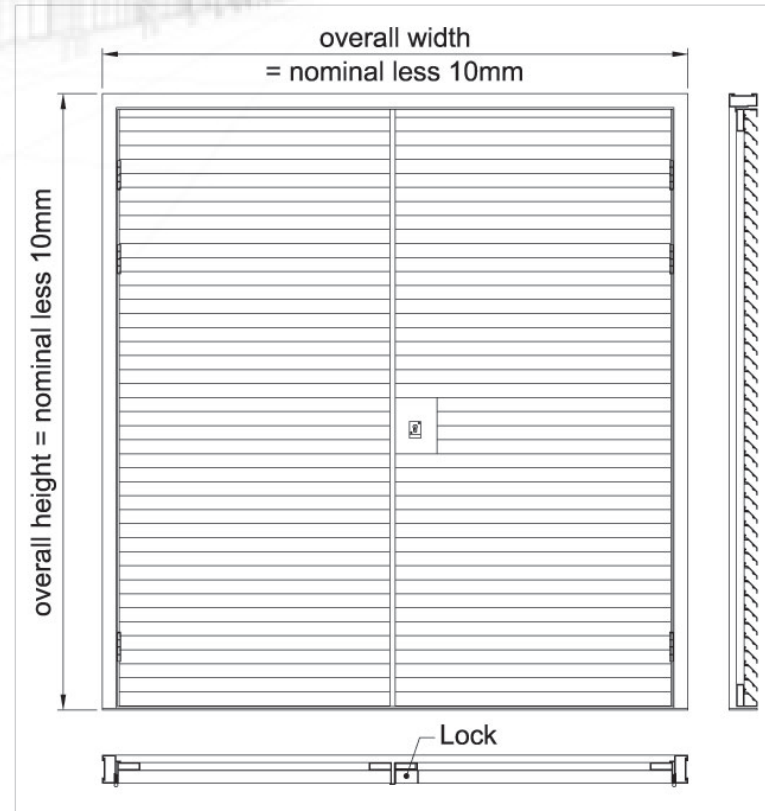

**Head detail**

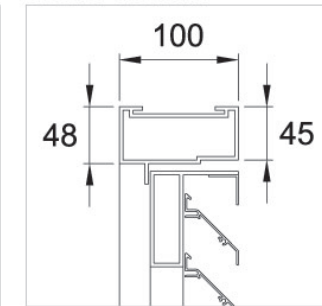

**Jamb detail**

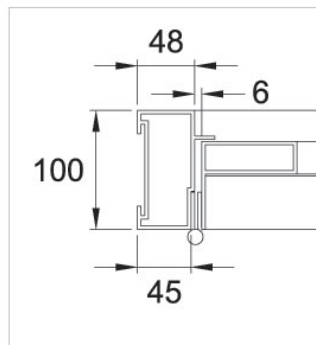

**Cill detail**

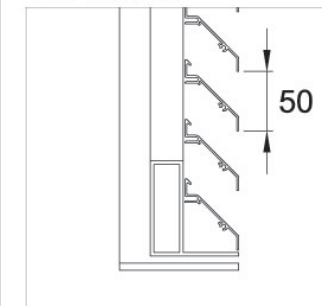

a total **louvre design**  
and **manufacturing** service

## **BL75LD Aluminium Louvred Door Specification**

Standard outer box frame dimensions: 50mm x 150mm

Door leaf depth: 110mm

Hinges: 3 no. 100 x 75mm ball bearing butt hinges with pin secured by removable grub screw

Louvre Blade pitch: 75mm

Lock case: 64mm euro profile deadlock to EN12209

Cylinder: Euro cylinder, keyed external, thumbturn internal.

Shoot bolts (double doors only): heavy duty brushed stainless steel 14mm diameter

Bird guard mesh: Galvanised after manufacture to BS443. Size 12.5mm x 12.5mm x 1mm. Fitted as standard.

Standard hardware correct as at June 2011 (may change without notice)

BL-LD Series Options are listed on page 7

a total **louvre design**  
and **manufacturing** service

**Single door**

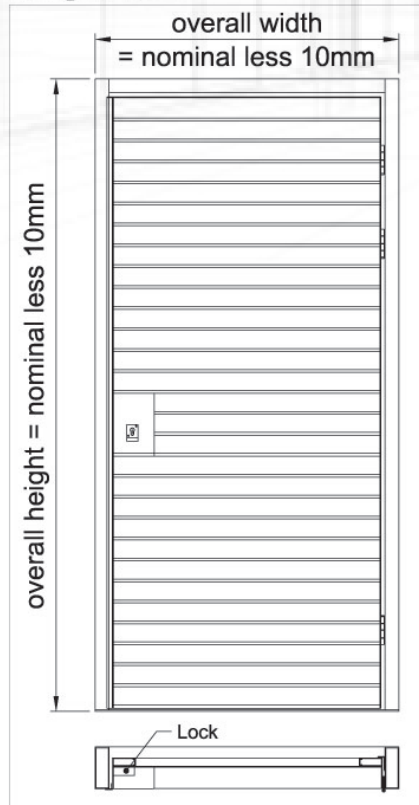

**Double door**

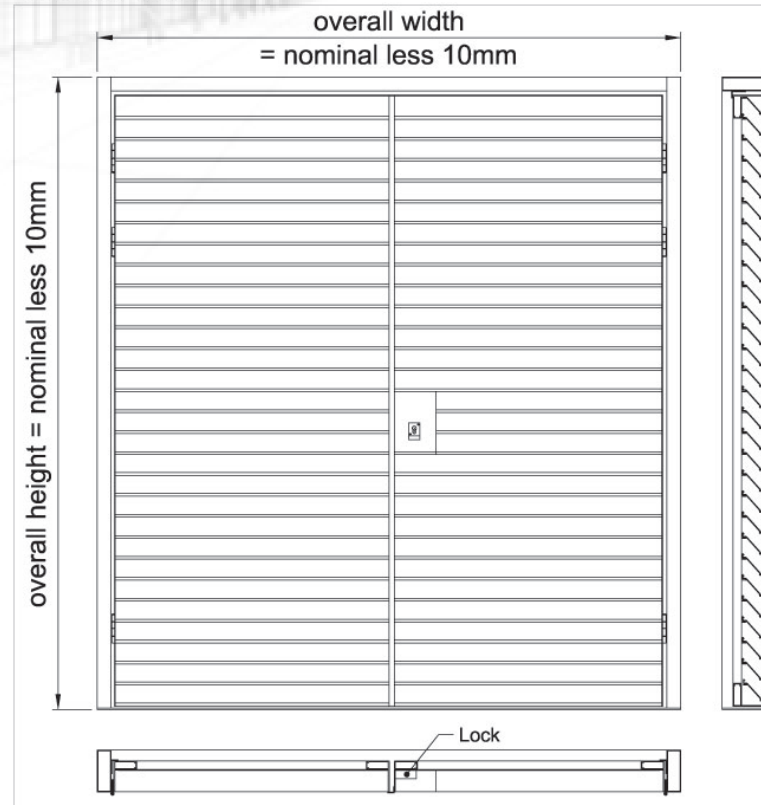

**Head detail**

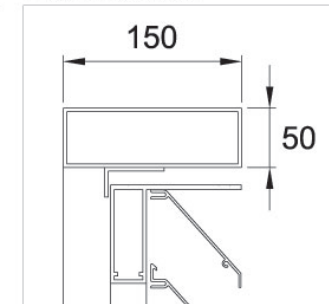

**Jamb detail**

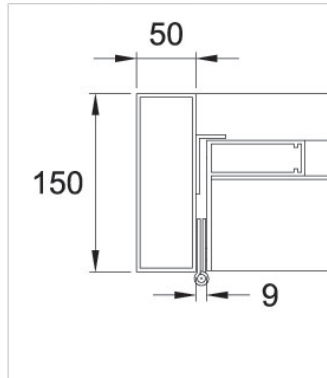

**Cill detail**

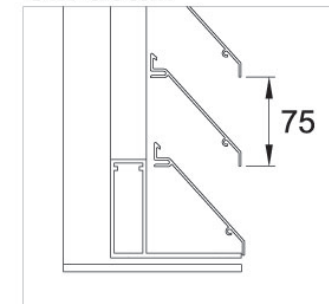



COMPANY  
LIMITED

**BL-LD Series  
Louvred Doors**

a total **louvre design**  
and **manufacturing** service



### Options

- Continuous aluminium hinge (geared hinge) with capping
- Emergency escape hardware (with or without external access device)
- Sash lock
- Insect Screens.
- Blanking Panels, single skin or insulated
- Vermin Guard
- Flush bolts
- Chain bolts (recommended on double doors over 2200mm high)
- Door stays (recommended on all doors unless closer fitted)
- Door closers
- Customers hardware/ironmongery
- Removable transom and overpanels.
- Alternative louvre blade configurations including double bank
- Mild steel, (zinc metal spray protection prior to powder coating)
- Inward opening

### Finishes

- Unfinished aluminium (mill finish)
- Architectural grade Polyester Powder coatings to any standard RAL or BS 4800 range colours.
- Anodised
- Special finishes including timber effect on request.



COMPANY  
LIMITED

## BL-50BF Insert Louvre Panels for Doors

a total **louvre design**  
and **manufacturing** service

### BL50BF Series - Insert Louvres for Doors

Aluminium extrusions type 6063-T6 to BS1474 having a minimum thickness of 1.6mm . Mitred frame joints TIG welded for additional strength.

The louvre comprises louvre blades inclined at 45° and mounted at 50mm pitch within 50mm deep frame for mounting within standard 45mm thick door. Galvanised bird screen supplied as standard. Frames can be flanged for surface mounting or recessed to give frameless appearance. The bottom blade is extended over the outer frame to prevent ingress of water and provide drainage from the louvre face. **Louvre complete with with back frame for return side of door**, to mask any rough cut edges.

Louvre blades secured by a minimum of four no.8 x 19 screws per blade to provide robust assembly.

Louvre sizes made to suit customer requirements.

Nominal free area: 50%

Maximum BSRIA weather test rating (simulated rainfall of 75mm/hr, wind speed of 13m/sec): 89.42% Class C

Face Velocity (metres per second)	0.5	1.0	1.5	2.0
Pressure drop (Pascals)	2.48	9.91	22.3	39.65

a total **louvre design**  
and **manufacturing** service

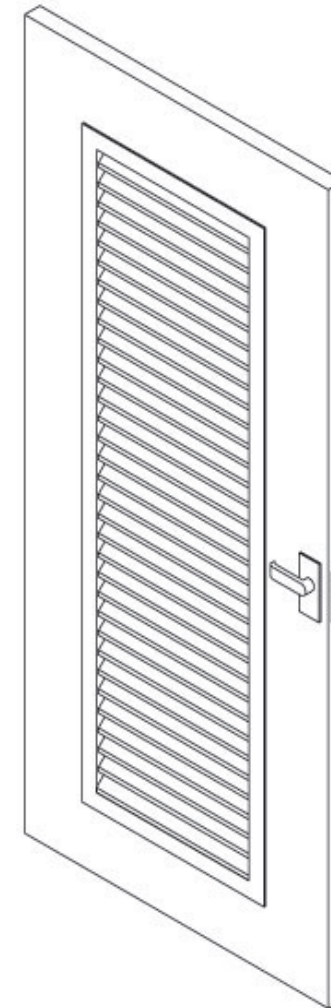
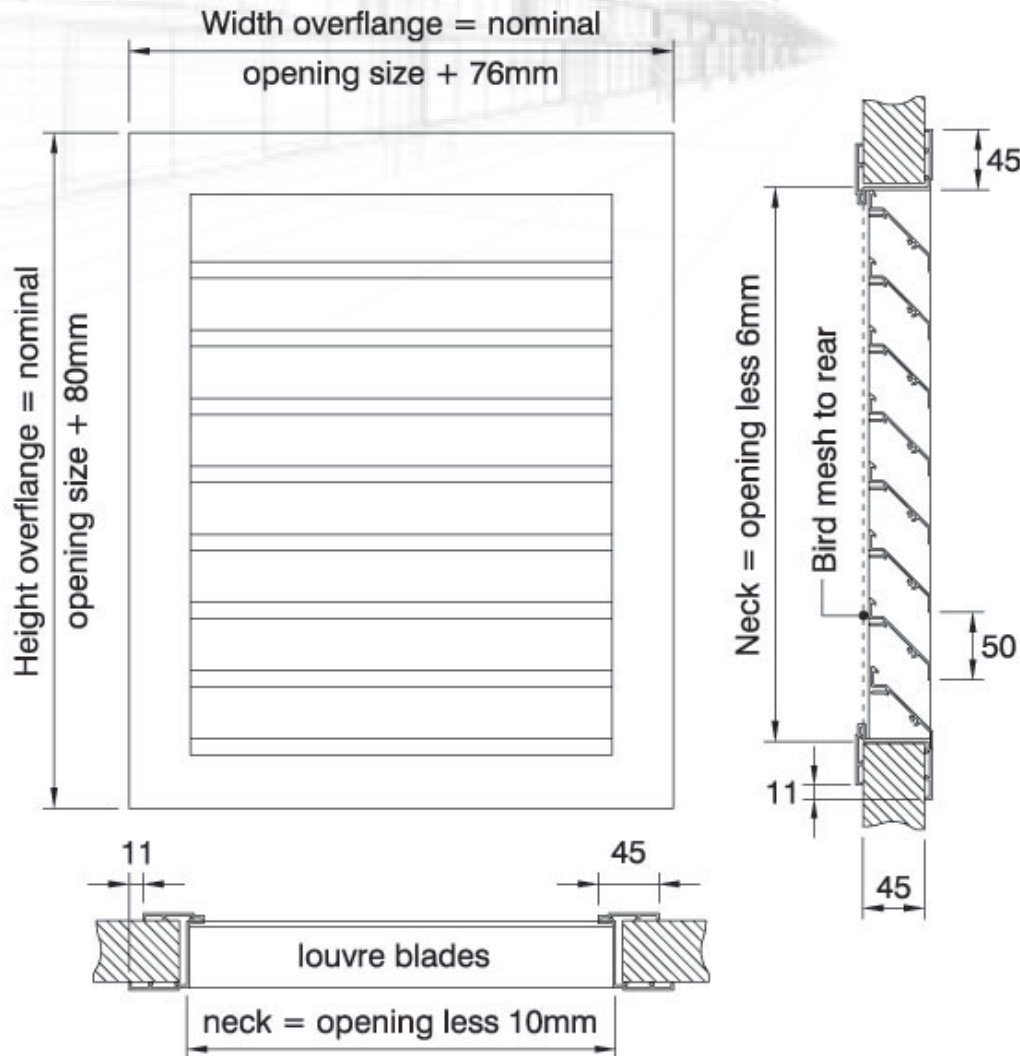

a total **louvre design**  
and **manufacturing** service



#### Fixing

Supplied as standard with flanges undrilled. Fixing through flange or neck.

#### Options

- Insect Screen.
- Blanking Panels (single skin plate or insulated blanking panel)
- Vermin Guard
- Removable core/hinged core
- Alternative blade pitches
- Panels to suit non-standard door depths

#### Finish

- Mill finish as standard (untreated and unpolished aluminium).
- Polyester Powder coatings to any standard RAL or BS 4800 range colours.
- Special finishes available on request.